

PARAGON KILN MODELS A-82B, A-82B-3, A-81-B, A-88B, AA-8B and AA-8B-3

WIRING DIAGRAMS AND PARTS IDENTIFICATIONS

**WHEN ORDERING PARTS,
ALWAYS SPECIFY
MODEL NUMBER,
REFERENCE NUMBER,
PART NUMBER,
AND DESCRIPTION**

For prices of parts, see your current
Paragon Kiln Catalog Price List.
All prices are F.O.B. factory, Dallas County, Texas
and are subject to change without notice.

The models available for the CSA label
have the kiln wiring terminated in a
special box on the kiln for stationary installation.

**MERCHANDISE TO BE SHIPPED TO ONE ADDRESS
ON ONE ORDER *MUST TOTAL \$5.00* BEFORE
THE POSTAGE AND HANDLING CHARGES ARE ADDED.**

**Model Numbers ending in "3" have special
3" walls. The letter "B" following the Model
Number means the kiln has a stainless steel jacket.**

EXTENSION COLLARS AA-8B, AA-8B-3, and AA-8

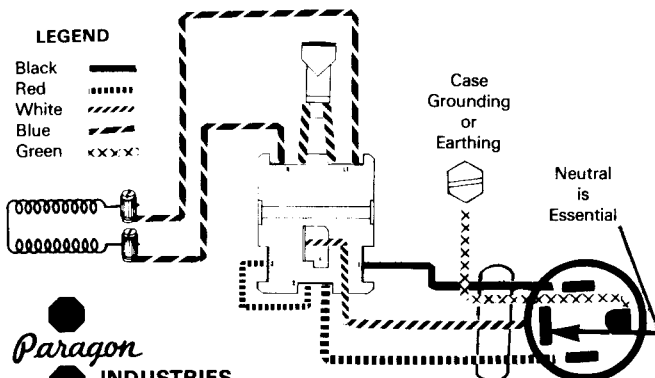

**MODELS A-82B, A-81B, A-88B and A-88
(4-way Rotary Switch With Screw-on Terminals)**

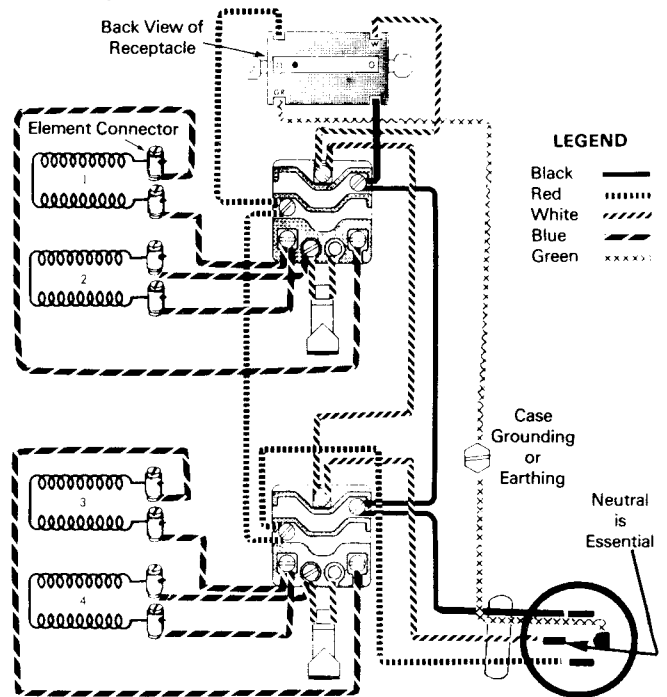

**MODELS A-82B, A-82B-3, A-81B, A-88B and A-88
(4-way Rotary Switch with Push-on Terminals)**

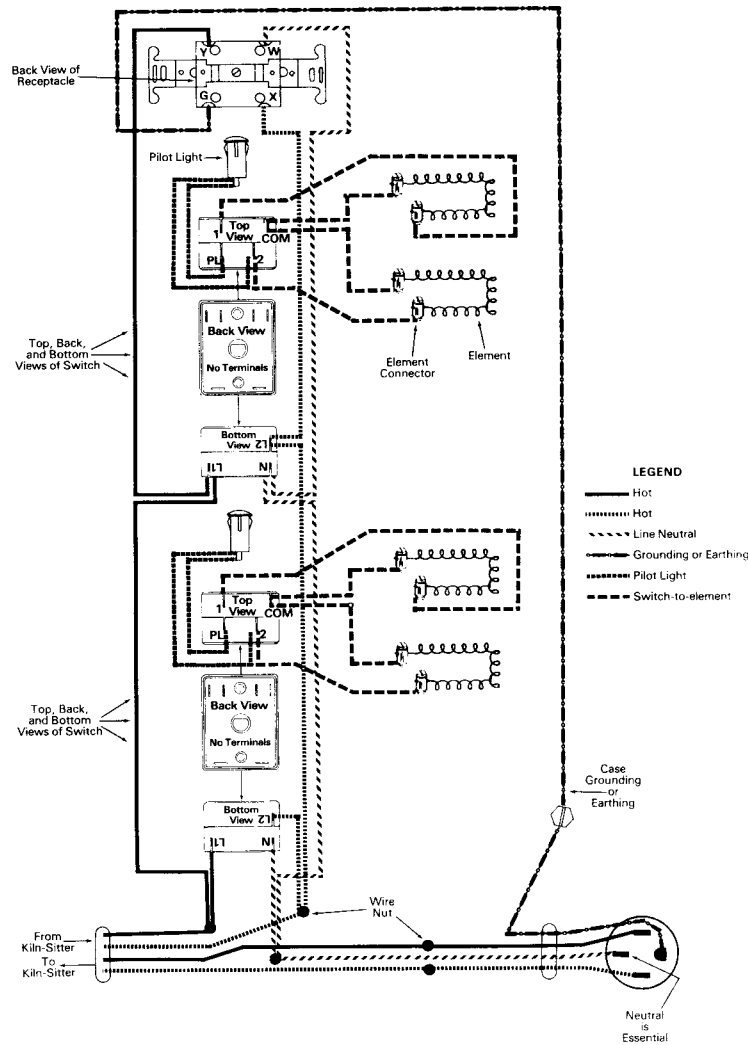

Paragon
INDUSTRIES
BOX 808
MESQUITE, TEXAS 75149 - 0170

Specify complete model number when ordering insulating firebrick, metal jacket parts, and elements.

A-82B, A-82B-3, A-81B, A-88B and A-88

REF. NO.	PART NO.	DESCRIPTION
1.	Specify Model	METAL JACKET PARTS
2.	Specify Model	Hinge, complete, gray or brown
3.	Specify Model	Form-Fitted Jacket, stainless
4.	Specify Model	Full-Formed Steel Base
5.	Specify Model	Heat Shield
5.	Specify Model	Ventilated Switch Box, gray or brown (box only)
6.	Specify Model	INSULATING FIREBRICK
7.	Specify Model	Brick Lid with Band, stainless (less hardware)
8.	Specify Model	2" Plain Wall Brick
9.	Specify Model	4" Straight Grooved Wall Brick
8.	Specify Model	4" Peephole Wall Brick
10.	Specify Model	4" Terminal Wall Brick
11.	Specify Model	4" Kiln-Sitter Wall Brick
12.	Specify Model	Brick Bottom, only
13.	EL.A-82 or EL.A-88	ELECTRICAL PARTS
		Heating Element for A-82B, A-81B
		Heating Element for A-88B, A-88
14.	EL.A-82-3	Heating Element for A-82B-3
	WR-2 or WR-4	#14 Switch-to-Element Lead Wires, screw-on eyelet both ends
		#14 Switch-to-Element Lead Wires, push-on terminal one end
15.	WR-14	#14 Double Switch-to-Element Lead Wires, push-on terminal one end
16.	WR-11	Sitter-to-Switch Box Jumper Wires, for kilns equipped with kiln sitter (not shown)
17.	MS-5	Large Wire Connector
18.	WR-12 or WR-13	Receptacle-to-Switch Connecting Wires, screw-on eyelet both ends
		Receptacle-to-Switch Connecting Wires, push-on terminal one end
19.	RC-1	Receptacle, 4-wire, 20 amp., 125/250 v. for kiln's switch box
20.	WR-6 or WR-7	Switch-to-Switch Connecting Wires, screw-on eyelet both ends
		Switch-to-Switch Connecting Wires, push-on terminal both ends
21.	SW-4	Switch, 26 amp., A-21 4-way Rotary for push-on terminals
22.	KN-1 or KN-3	Knob for 4-way Rotary Switch TAAP or TAAO, black center
		Knob for 4-way Rotary Switch A-21, silver center
23.	MS-7 or MS-8	Pilot Light with Lead Wires, eyelet terminals
		Pilot Light with Lead Wires, push-on terminals
24.	CR-2	6-4, 50 amp., 240 v., 6 ft. cord with 4-prong plug
25.	MS-6	Element Connectors
26.	MS-1	Porcelain Insulators (1 1/8" long)
27.	HW-1	OTHER REPLACEMENT PARTS
28.	HW-6	Lock-in Lid Support for A-series (7 and 8 sides)
29.	ST-2	Hand Lifts for A-series
30.	ST-1	Kiln Stand
		Plastic Feet, only
31.	HW-8	#8 Plated Metal Screws
32.	HW-7	Fall Away Prop-R-Vent Kit
33.	HW-4	Lid Handle, for small A-series (8-sided or less)
34.	PL-2	Peephole Plug, Cone Shaped for A-series
35.	Specify Model	Conduit for Kiln Sitter Wires (not shown)
36.	Specify Model	Cord Clamp

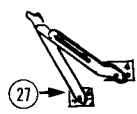

ALL LIDS MUST BE HAND-FITTED BECAUSE OF VARIATION IN FIRED CLAY PRODUCTS

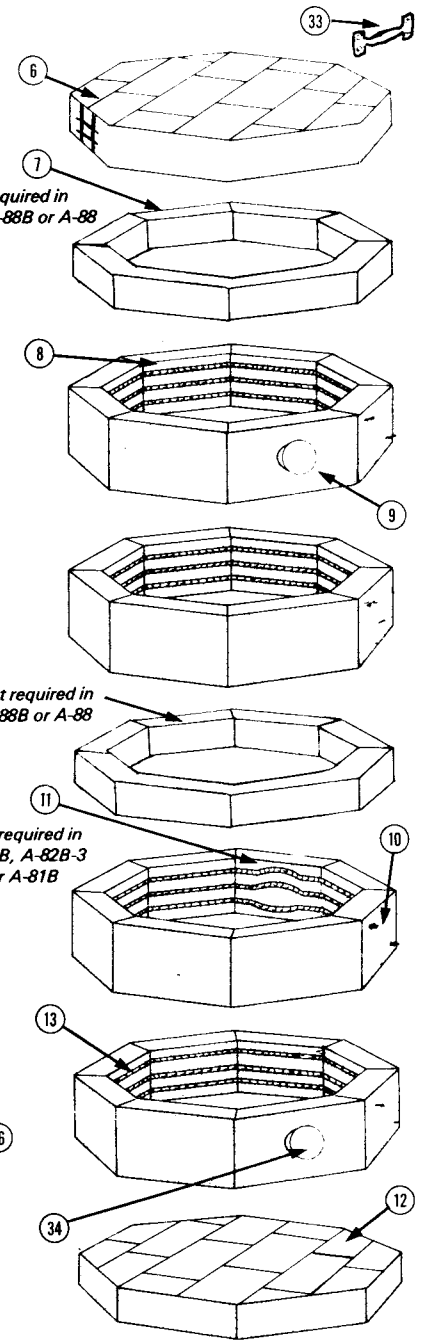
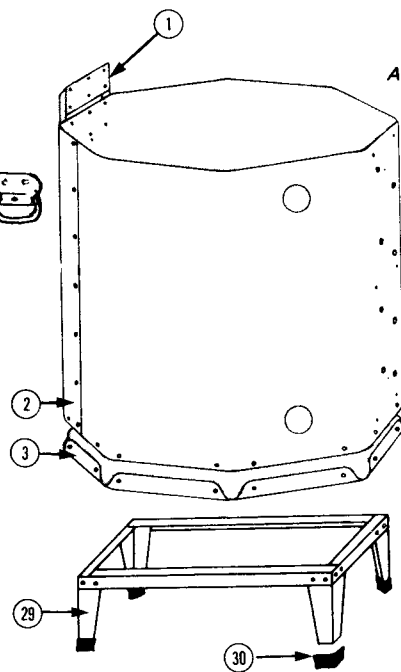

Not required in A-81B, A-88B or A-88

Not required in A-88B or A-88

Not required in A-82B, A-82B-3 or A-81B

AA-8B, AA-8B-3, and AA-8

1.	Specify Model	Hinge, lower half, gray or brown
2.	Specify Model	Form-Fitted Jacket, stainless
3.	Specify Model	4" Straight Grooved Wall Brick
4.	Specify Model	2" Straight Grooved Wall Brick
5.	EL.A-AA8 or EL.A-AA8-3	Heating Element for AA-8B, AA-8
6.	Specify Model	Heating Element for AA-8B-3
7.	Specify Model	2" Terminal Wall Brick
8.	Specify Model	4" Terminal Wall Brick
9.	PL-2	Peephole Plug, Cone Shaped for A-series
10.	Specify Model	Heat Shield
11.	MS-1	Porcelain Insulators (1 1/8" long)
12.	MS-6	Element Connectors
13.	WR-2	#14 Switch-to-Element Lead Wires, screw-on eyelet both ends
		#14 Switch-to-Element Lead Wires, push-on terminal one end
14.	WR-6	Switch-to-Switch Connecting Wires, screw-on eyelet both ends
15.	SW-3	Switch, 20 amp., 3-way Rotary
16.	Specify Model	Ventilated Switch Box, gray or brown (box only)
17.	KN-2 or KN-5	Knob for 3-way Rotary Switch, black center
		Knob for 3-way Rotary Switch, silver center
18.	MS-7	Pilot Light with Lead Wires, complete
19.	CR-7	14-4, 240 v., 3 ft. Cord with 4-prong plug
20.	HW-8	#8 Plated Metal Screws

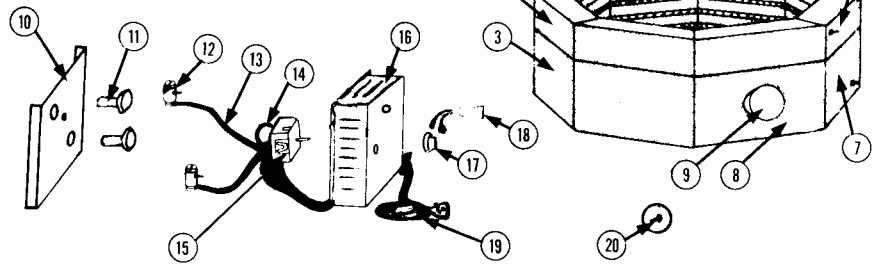
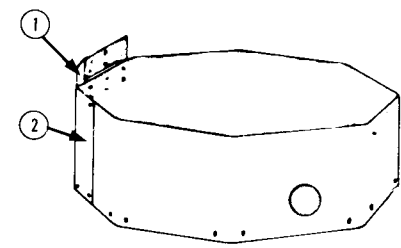

INSULATING FIREBRICK PARTS ARE INTERCHANGEABLE AMONG MODELS A-82B, A-81B, A-88B and A-88, EXCEPT WHERE OTHERWISE INDICATED